

# EASTERN INSTRUMENTS

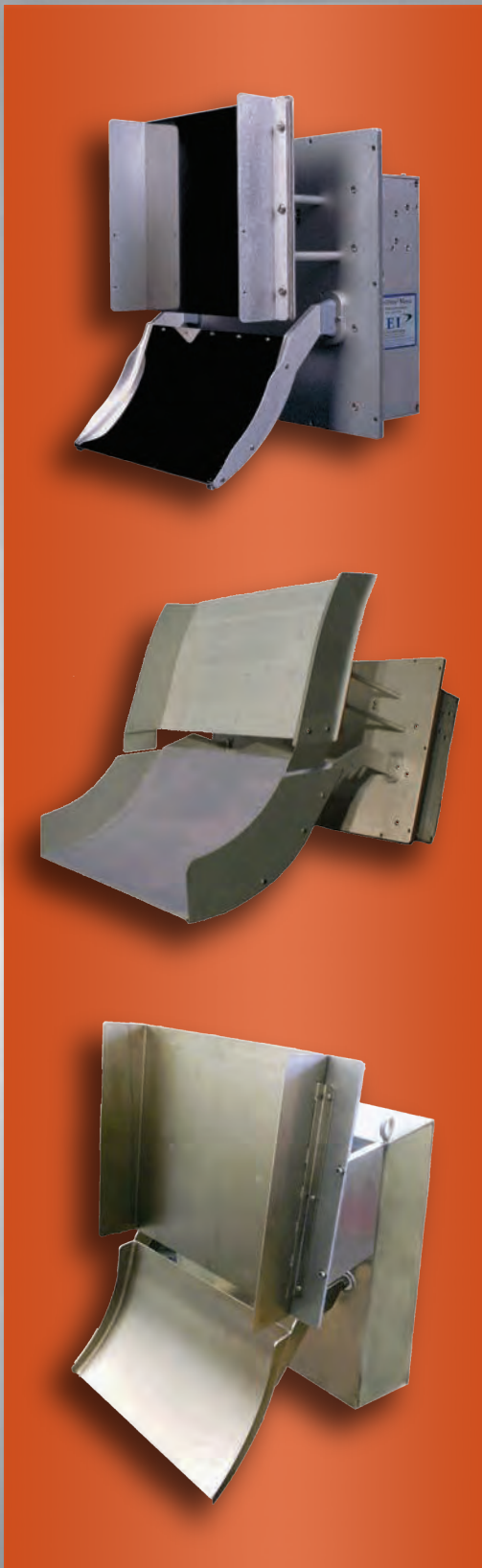

## TYPE I SOLIDS MASS FLOW METERS



**CentriFlow**<sup>®</sup>  
EASTERN INSTRUMENTS

Precision Material Handling Equipment

# Eastern Instruments Material Handling Solutions

## About Eastern Instruments

Eastern Instruments, a Certified Women's Business Enterprise, is an engineered solutions company located adjacent to the North Carolina International State Port in Wilmington, North Carolina. Since 1984, we have been engaged in the design and manufacture of devices that measure and control the flow of industrial bulk solids. These devices have been integrated into a variety of systems for regulating operations and improving efficiency across nearly every industrial sector. Every device within Eastern Instruments' solids flow measurement product line provides a high degree of accuracy, easy installation, a minimal footprint and extremely simple and intuitive operation and maintenance for both continuous and batch operations.

The following catalog is for our Type I Mass Flow Meters. Additional catalogs for each of our other product lines are available for more information on all of our products. If you are in need of quality material handling equipment, look no further; Eastern Instruments can help.

Contact us today.

*Mildred R. Brandt*  
President and CEO

FOR MORE INFORMATION  
CALL (910) 392-2490



416 Landmark Drive  
Wilmington, NC 28412  
Phone: 910.392.2490  
Fax: 910.392.2123  
[www.easterninstruments.com](http://www.easterninstruments.com)



## Applications



## Type I Flow Meters

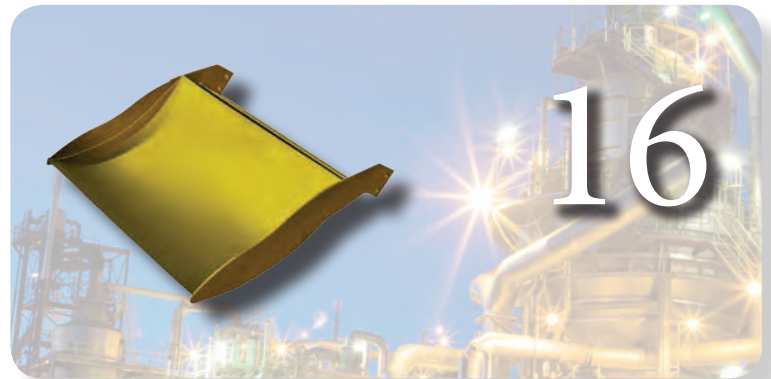

## Options



## Electronics

# The Principle of Centripetal Force and the Science Behind our Material Handling Equipment

Why are the solids flow measurement and control devices from Eastern Instruments so accurate? The secret lies in their zero-friction patented design, which is based on the principle of centripetal force.

Centripetal force is the inward force required to keep an object moving in a circular path. It can be shown that an object moving in a circular path has acceleration towards the center of the circle along a radius.

This radial acceleration, called the centripetal acceleration, is such that if an object has a linear or tangential velocity when moving in a circular path of radius (R), the centripetal acceleration is  $v^2/R$ . If the object undergoing the centripetal acceleration has a mass (M), then by Newton's second law of motion, the centripetal force (Fc) is in the direction of acceleration. This is expressed by the formula:

$$\text{Force} = \frac{\text{Mass} \times \text{Velocity}^2}{\text{Radius}}$$

From Newton's first law of motion, it follows that the natural motion of an object is one with constant speed in a straight line and that a force is necessary if the object is to depart from this type of motion. The force present when an object moves in a curve is called centripetal force.

The CentriFlow<sup>®</sup> Meter and all of the products in our Solids Flow Measurement Product Line actually measure the centripetal force exerted on the curved surface, in this case, the Measurement Pan, as particles travel over it. The meter does not measure the impact of particles because they never impact the Measurement Pan. Rather, they slide across the Pan for a longer duration, thus resulting in a significantly more accurate signal.

Based on the patented design of these unique devices, they are able to identify and cancel the friction component and, when combined with a velocity that is constant and a radius that is unchanging, the flow equals mass. In this manner, the flow signal from our devices is an actual mass flow, which is linear and accurate, and is not affected by density or slight particle size variations. This is Zero Friction Flow Measurement.

Measures Centripetal Force, not the Impact of Particles

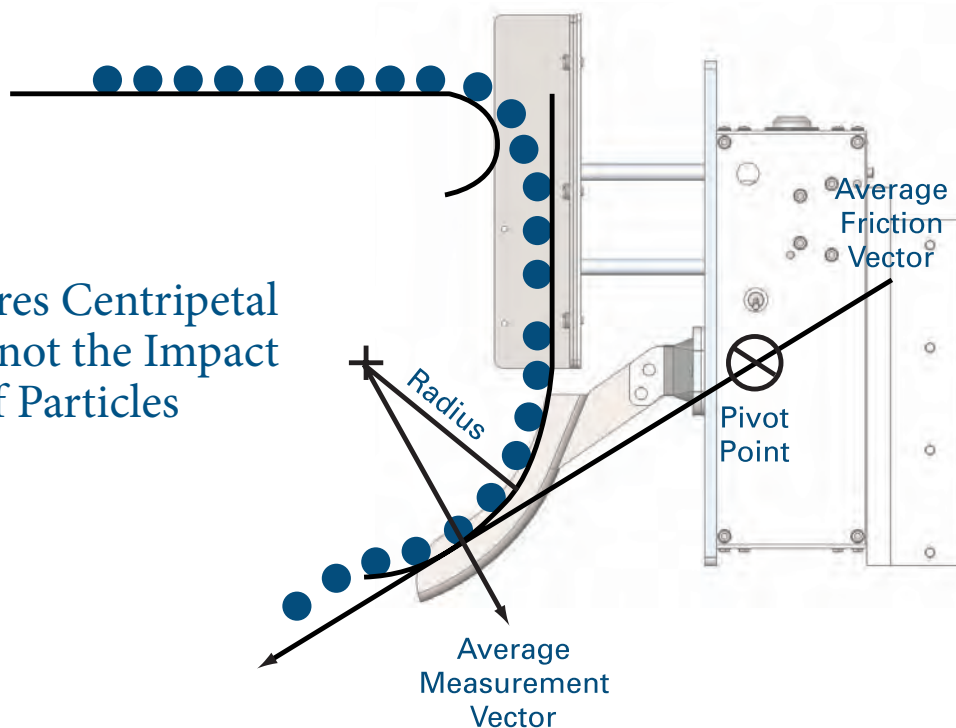

# Applications

## Construction

- Drywall/Plywood
- Concrete Products
- Engineered Materials
- Recycled Materials
- Roofing Products
- Asphalt Products



## Petrochemical

- Rubber Products
- Oil Extraction
- Petrochemicals
- Plastics/Additives



## Agricultural

- Beans/Grains
- Nuts
- Fertilizers/Additives
- Corn Products



The CentriFlow Meter:  
Exceeding Expectation  
in Any Industry.  
Contact Us Today.

## Industrial Chemicals

- Industrial Powders
- Consumer Goods
- Glass Ceramics
- Mining



## Energy Production

- Bio-Energy Feedstocks
- Ethanol Production
- Renewable Energy
- Coal-Fired Energy



## Food

- Baked Goods
- Beans and Grains
- Dried Foods
- Snack Foods/Cereals
- Beverages
- Tobacco Products



## Pet Products

- Feed Pellets
- Additives
- Kibble
- Litter/Bedding

## Recycling

- Recycled Plastics
- Renewable Energy
- Construction Materials
- Asphalt Production

CENTRIFLOW<sup>®</sup>: ACCURATE MEASUREMENT FOR MANY APPLICATIONS



## Why choose the CentriFlow®?

### Accuracy

Unlike existing technologies that *calculate* mass flow by making assumptions based on weight, speed, belt tension, or volume, the CentriFlow® Meter actually *measures* flowable solids in a process. This unique measurement ability allows the CentriFlow® Meter to have a typical  $\pm 0.25\%$  accuracy full scale on virtually all flowable solids, significantly improving the industry standard.

### Turndown Ratio

The CentriFlow® Meter can maintain its accuracy over a large turndown ratio and an additional Multiple Calibration option is available for extreme turndowns. Because the meter's unique design enables it to identify and cancel the friction component, the resulting mass flow signal = mass rate. This linear relationship allows the meter to measure at a typical accuracy of  $\pm 0.25\%$  full scale and is unaffected by wide variances in rate.

### Solid Construction / Low Maintenance

The CentriFlow® Meter's sturdy high-grade aluminum construction and stainless steel flow paths create a very low maintenance instrument. With no moving parts, it rarely requires recalibration and its solid-construction, low-maintenance design requires very few spare parts.

### Plant Efficient Configurations

Designed to fit into nearly any existing process, the CentriFlow® Meter is available in multiple configurations that minimize the need for costly changes to your process. The Type I Configuration is designed to mount at the end of any existing horizontal feed system, while the Type II Configuration is designed for any in-line vertical feed system. Compared to alternatives, the CentriFlow® Meter's compact, space efficient design requires a small footprint.

### Flexibility

The CentriFlow® Meter is not affected by changes in product elasticity, density, shape or friction and even fluctuations in flow rate don't impact its accuracy. The linearity of the zero friction formula underlying the meter's design allows the CentriFlow® Meter to measure at various densities and turndown ratios, while maintaining near perfect accuracy.

### Continuous Measurement for Continuous Improvement

The CentriFlow® Meter's ability to provide an accurate and real-time, continuous mass flow measurement allows you to optimize your process like never before. The ability to measure gives you the control to manage.

VISIT EASTERN INSTRUMENTS ON  FOR PRODUCT VIDEOS



# Solids Flow Meters

The CentriFlow® Type I Meter is a solids mass flow meter designed to measure bulk solids continuously in a process and is specially designed to be installed directly after feed devices that move material in a horizontal direction such as belts or vibratory conveyors. Perfect for installation in both new construction or retrofitted into existing processes, the CentriFlow® Type I Meter has a minimal vertical footprint that can be installed within as little as 20" of height. With a wide variety of options for flow surfaces, the Type I meter can be optimized to measure nearly any product, from highly abrasive industrial materials to delicate foods such as chips.

As the CentriFlow® Type I Meter is an open style meter (not enclosed), it is typically used to measure products that are relatively free-flowing and non-powdery in nature. Examples of such products include granules, pellets or even bulky materials like snack food or chips. Its open concept even lends itself to processes that require periodic wash downs or frequent access to the product or the meter's flow surfaces.

The Type I Meter is available in several specialized models which range in scope from low flow and low density applications to very high flow and high density products or applications. With a variety of meter models and an abundance of options, the Type I Meter can be custom tailored to the characteristics of your particular product. The Type I Meter can be installed in several installation orientations as well, meaning that the meter can be customized for your particular product and installed in a way specific to your particular process. These orientations allow the product's flow to either continue flowing in the same direction as the feed device (In-Line), or in the opposite direction (Reverse Flow). Please see the following page for more information.

With a variety of customizable features and models to choose from, there is a CentriFlow® Type I Meter designed with your process in mind.

## CentriFlow®: Type I Models

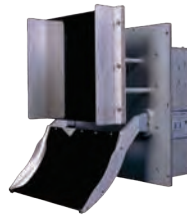

### CFM Type I: Standard

- Open Meter Style
- Perfect for Most Applications
- Fed by Vibratory/Belt Conveyor
- For Free-Flowing Products

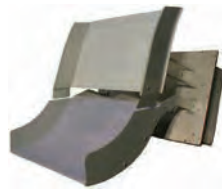

### LDM Type I: Light Density

- Open Meter Style
- Fed by Vibratory/Belt Conveyor
- Perfect for Large, Bulky Materials
- For Light Density Materials



### CFL Type I: Low Flow

- Open Style Meter
- Includes Pan Shroud
- Perfect for Very Low Flow Rates
- Fed by Vibratory/Belt Conveyor
- For Free-Flowing Products



### HDM Type I: Heavy Duty

- Open Meter Style
- Heavy, High-Density Materials
- Very High Flow Rates

## CentriFlow®: Type I Installations

### Type I - In Line Flow

There are two ways to install the CentriFlow® Type I Meter, in the Reverse Flow orientation and in the In Line Flow orientation. An In Line Flow installation allows product travelling in a particular direction to continue travelling in that direction, even as it exits the CentriFlow® Meter. This type of installation ensures the least amount of damage to delicate products and is ideal for delicate materials such as chips or snack foods.

Installing the CentriFlow® Meter in the In-Line orientation typically requires a transition between the feed device (installed before the CentriFlow® Meter) and the meter itself so that product is properly presented to the meter. Transitions are often provided by Eastern Instruments, however, assistance can be provided with modelling and design of the transitions should the transitions be fabricated by a third party.

### Type I - Reverse Flow

As with the In Line flow orientation, all models of the CentriFlow® Type I Meter can be utilized in the Reverse Flow orientation as well. The Reverse Flow orientation allows product travelling in a particular direction to reverse and continue flowing in the opposite direction as it exits the CentriFlow® Meter. The Reverse Flow orientation requires the least vertical space as the meter can be positioned directly at the end of a belt or vibratory conveyor in as little as 20" of vertical space.

Installing a CentriFlow® Type I Meter in the Reverse Flow orientation is an extremely simple installation that rarely requires the use of transitions from the feed device to the meter. There are some instances, however, in which a transition from a vibratory conveyor may be required in order to properly present product to the CentriFlow® Meter for measurement.

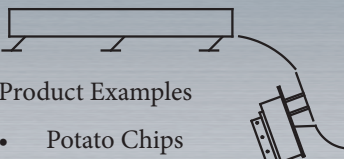
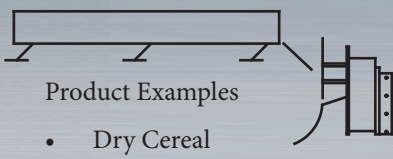
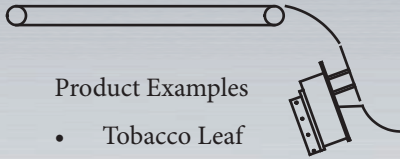
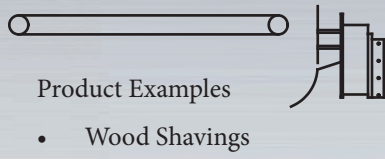

<b>Vibratory Feed</b> 		<b>Vibratory Feed</b> 	
<b>Product Types</b> <ul style="list-style-type: none"> <li>• Bulky</li> <li>• Large-Particle</li> <li>• Fragile</li> <li>• Free-Flowing</li> </ul>	<b>Product Examples</b> <ul style="list-style-type: none"> <li>• Potato Chips</li> <li>• Tortilla Chips</li> <li>• Nuts</li> <li>• Grains</li> </ul>	<b>Product Types</b> <ul style="list-style-type: none"> <li>• Cohesive</li> <li>• Sticky</li> <li>• Fragile</li> <li>• Light</li> </ul>	<b>Product Examples</b> <ul style="list-style-type: none"> <li>• Dry Cereal</li> <li>• Shredded Cheese</li> <li>• Dried Parsley</li> <li>• Frozen Vegetables</li> </ul>
<b>Belt Feed</b> 		<b>Belt Feed</b> 	
<b>Product Types</b> <ul style="list-style-type: none"> <li>• Bulky</li> <li>• Large-Particle</li> <li>• Fragile</li> <li>• Free-Flowing</li> </ul>	<b>Product Examples</b> <ul style="list-style-type: none"> <li>• Tobacco Leaf</li> <li>• Frozen Vegetables</li> <li>• Dry Cereal</li> <li>• Grains</li> </ul>	<b>Product Types</b> <ul style="list-style-type: none"> <li>• Cohesive</li> <li>• Fragile</li> <li>• Heavy</li> <li>• Sticky</li> </ul>	<b>Product Examples</b> <ul style="list-style-type: none"> <li>• Wood Shavings</li> <li>• Dry Cereal</li> <li>• Aggregate</li> <li>• Fertilizer</li> </ul>

# CFM Type I: Standard

The CFM Type I Standard Meter is exceedingly versatile and can be utilized for nearly any application requiring a mass flow measurement in which the product is being fed in a horizontal direction. The CFM Type I Standard Meter is perfect for large products such as tortilla chips or cereals, as well as smaller, more granular products such as pellets or grains. Type I CentriFlow® Meters, can be mounted in either the Reverse or the In-Line Flow orientation. While both orientations of the meter are mechanically identical, when oriented in the In-Line orientation, the meter can be tilted backwards (up to 20 Degrees) in order to facilitate the movement of product through the meter. In addition, a transition (pictured below) is often needed in order to move product from the feed device to the meter. The transition can be supplied by Eastern Instruments or by a third party as well.



Typical In-Line Feed Transition

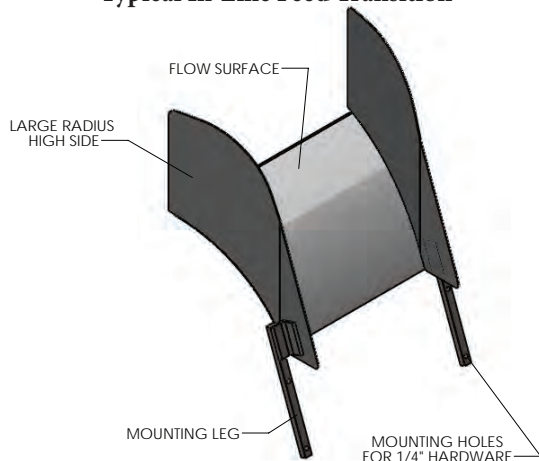

## Material Specification

1. Standard meter parts (those other than product contact surfaces) are constructed of 6061 aluminum. Stainless Steel also available.
2. Standard product contact surfaces (parts within the flow path) are constructed of Stainless Steel.
3. Stainless Steel liners are available for high-wear applications and can be manufactured with a variety of coatings.
4. A selection of liners and a variety of materials of construction are available as required by your application.

Volumetric Capacity of the CentriFlow® Meter for REVERSE FLOW ft<sup>3</sup>/min (m<sup>3</sup>/hr)

Meter Size	Belt		Vibratory	
	Min	Max	Min	Max
CFM-03	0.13 (0.21)	2.50 (4.25)	1.25 (2.12)	3.75 (6.37)
CFM-06	0.34 (0.57)	6.75 (11.47)	3.38 (5.73)	10.13 (17.20)
CFM-12	0.75 (1.27)	15.00 (25.49)	7.50 (12.74)	22.50 (38.23)
CFM-24	1.50 (2.55)	30.00 (50.97)	15.00 (25.49)	45.00 (76.46)
CFM-36	2.25 (3.82)	45.00 (76.46)	22.50 (38.23)	67.50 (114.68)
CFM-48	3.00 (5.10)	60.00 (101.94)	30.00 (50.97)	90.00 (152.91)

Volumetric Capacity of the CentriFlow® Meter for IN-LINE FLOW ft<sup>3</sup>/min (m<sup>3</sup>/hr)

Meter Size	Belt		Vibratory	
	Min	Max	Min	Max
CFM-03	1.25 (2.12)	7.50 (12.74)	1.25 (2.12)	3.75 (6.37)
CFM-06	3.38 (5.73)	20.25 (34.40)	3.38 (5.73)	10.13 (17.20)
CFM-12	7.50 (12.74)	45.00 (76.46)	7.50 (12.74)	22.50 (38.23)
CFM-24	15.00 (25.49)	90.00 (152.91)	15.00 (25.49)	45.00 (76.46)
CFM-36	22.50 (38.23)	135.00 (229.37)	22.50 (38.23)	67.50 (114.68)
CFM-48	30.00 (50.97)	180.00 (305.82)	30.00 (50.97)	90.00 (152.91)



## TYPE I STANDARD SPECS

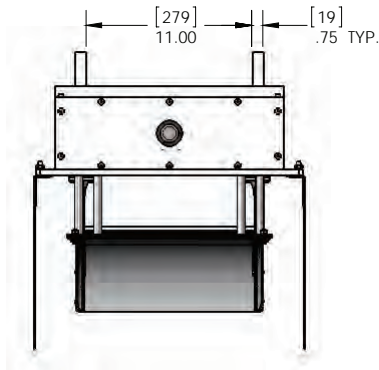

Top View

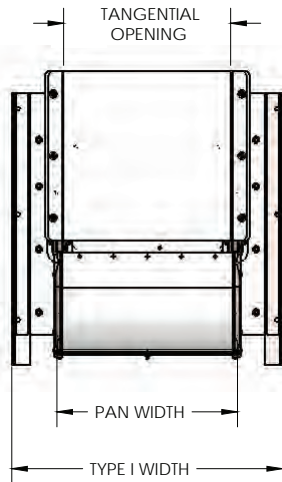

Front View

For Meters With  
An Enclosure  
Please See Our  
Type II Catalog

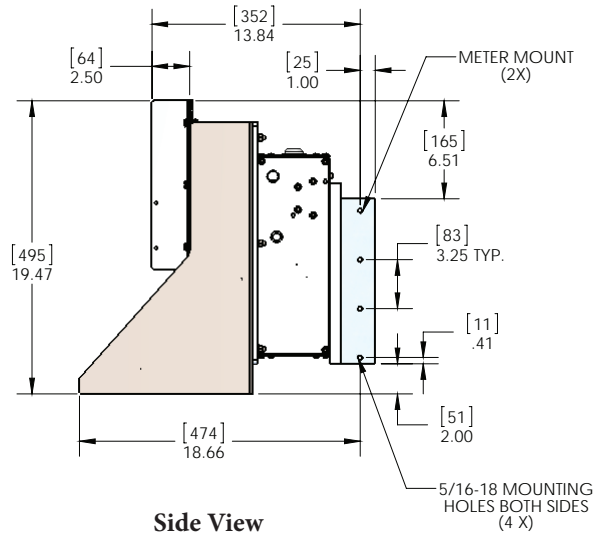
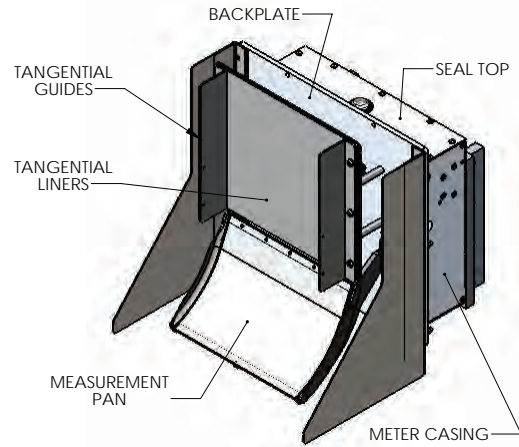

Side View

### Type I - Specifications

	Type I Width	Tangential Opening	Pan Width	Height	Weight (AL)	Weight (SS)	Installation Angle
CFM-03	12.00 in 305 mm	2.13 in 53 mm	3.00 in 305 mm	19.50 in 495 mm	60 lb 27 kg	125 lb 57 kg	0° Reverse Flow 0° - 20° In-Line
CFM-06	12.00 in 305 mm	5.13 in 130 mm	6.00 in 152 mm	19.50 in 495 mm	55 lb 25 kg	120 lb 54 kg	0° Reverse Flow 0° - 20° In-Line
CFM-12	18.00 in 457 mm	11.13 in 282 mm	12.00 in 305 mm	19.50 in 495 mm	65 lb 29 kg	150 lb 68 kg	0° Reverse Flow 0° - 20° In-Line
CFM-24	30.00 in 762 mm	23.13 in 587 mm	24.00 in 610 mm	19.50 in 495 mm	105 lb 48 kg	205 lb 93 kg	0° Reverse Flow 0° - 20° In-Line
CFM-36	42.00 in 1067 mm	35.13 in 892 mm	36.00 in 914 mm	19.50 in 495 mm	130 lb 59 kg	245 lb 111 kg	0° Reverse Flow 0° - 20° In-Line
CFM-48	54.00 in 1372 mm	47.13 in 1196 mm	48.00 in 1219 mm	19.50 in 495 mm	160 lb 73 kg	290 lb 131 kg	0° Reverse Flow 0° - 20° In-Line

# LDM Type I: Light Density

The CentriFlow® Light Density Meter (LDM) is a specialized version of the CentriFlow® Meter designed to measure low-density materials (typically products 10 lb/ft<sup>3</sup> or less). The radius of the Measurement Pan is twice that of the Standard CentriFlow® Meter. By enlarging the Measurement Pan's radius, the LDM is able to accommodate low-density, bulky, large-particle materials such as tobacco (whole leaf, strip, stems, processed leaf, etc.), wood chips, leafy vegetables and many other similar materials. The LDM is available in a variety of sizes to accommodate almost any product that is being fed from a belt or vibratory conveyor. Due to the bulky nature and the larger particle size of products typically fed through the LDM Meter, the meter is typically installed in the In-Line Feed orientation. It can, however, be installed in the Reverse Feed orientation as well.



## Material Specification

- Standard meter parts (those other than the product contact surfaces) are constructed of 6061 aluminum or Stainless Steel.
- Standard product flow surfaces (parts within the product flow path) are constructed of Stainless Steel or UHMW. Other materials are available.
- Stainless Steel liners with a variety of coatings are available for high-wear applications or applications where flow concerns are present.
- A variety of liners and coatings are available and can be substituted for the standard flow surfaces if required by the application.

## Design Specification

- The Pan is twice the radius of the standard CentriFlow® Type I Meter.
- The Tangential is curved and tilted back in order to improve product flow through the meter.
- Feed Transitions are rarely needed when installing the CentriFlow® LDM Meter.
- The LDM can be tilted back (up to 20 Degrees) to improve product flow.
- Custom Enclosures are available for enclosing the LDM Meter if required. Contact EI for details about this option.

Volumetric Capacity of the CentriFlow® LDM Meter for REVERSE FLOW ft<sup>3</sup>/min (m<sup>3</sup>/hr)

Meter Size	Belt		Vibratory	
	Min	Max	Min	Max
LDM-06	0.84 (1.43)	16.88 (28.67)	8.44 (14.34)	25.31 (43.01)
LDM-12	1.88 (3.19)	37.50 (63.71)	18.75 (31.86)	56.25 (95.57)
LDM-24	3.75 (6.37)	75.00 (127.43)	37.50 (63.71)	112.50 (191.14)
LDM-36	5.63 (9.56)	112.50 (191.14)	56.25 (95.57)	168.75 (286.71)
LDM-48	7.50 (12.74)	150.00 (254.85)	75.00 (127.43)	225.00 (382.28)

Volumetric Capacity of the CentriFlow® LDM for IN-LINE FLOW ft<sup>3</sup>/min (m<sup>3</sup>/hr)

Meter Size	Belt		Vibratory	
	Min	Max	Min	Max
LDM-06	8.44 (14.34)	50.63 (86.01)	8.44 (14.34)	25.31 (43.01)
LDM-12	18.75 (31.86)	112.50 (191.14)	18.75 (31.86)	56.25 (95.57)
LDM-24	37.50 (63.71)	225.00 (382.28)	37.50 (63.71)	112.50 (191.14)
LDM-36	56.25 (95.57)	337.50 (573.41)	56.25 (95.57)	168.75 (286.71)
LDM-48	75.00 (127.43)	450.00 (764.55)	75.00 (127.43)	225.00 (382.28)

## TYPE I LDM SPECS

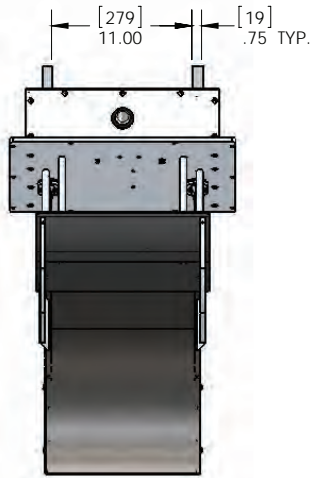

Top View

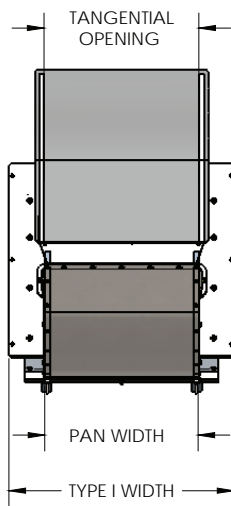

Front View

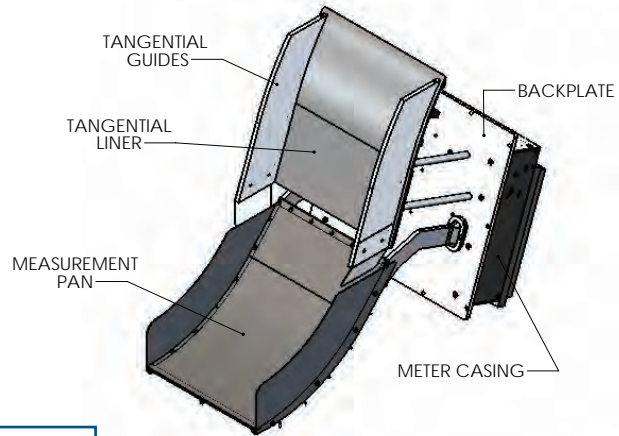

For Meters With  
An Enclosure  
Please See Our  
Type II Catalog

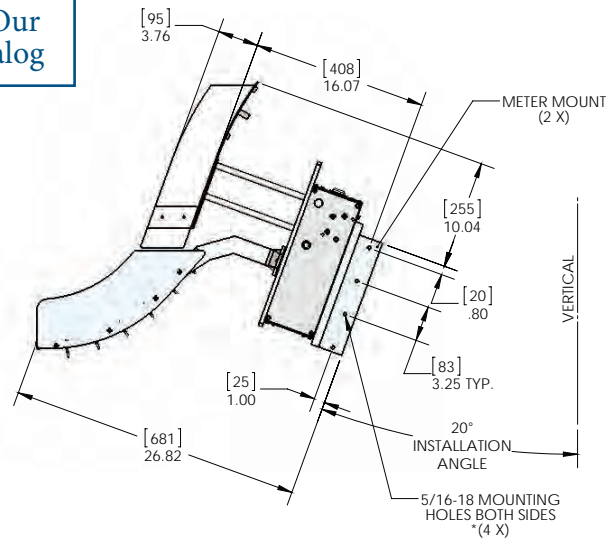

Side View

### Type I - Specifications

	Type I Width	Tang. Opening	Pan Width	Height	Weight (AL)	Installation Angle
LDM-06	12.00 in 305 mm	6.13 in 156 mm	6.00 in 152 mm	25.18 in 639 mm	60 lb 27 kg	0° - 20° In-Line
LDM-12	18.00 in 457 mm	12.13 in 308 mm	12.00 in 305 mm	25.18 in 639 mm	70 lb 32 kg	0° - 20° In-Line
LDM-24	30.00 in 762 mm	24.13 in 613 mm	24.00 in 610 mm	25.18 in 639 mm	100 lb 45 kg	0° - 20° In-Line
LDM-36	42.00 in 1067 mm	36.13 in 914 mm	36.00 in 914 mm	25.18 in 639 mm	125 lb 57 kg	0° - 20° In-Line
LDM-48	54.00 in 1372 mm	48.13 in 1219 mm	48.00 in 1219 mm	25.18 in 639 mm	150 lb 68 kg	0° - 20° In-Line

# CFL Type I: Low Flow

The CentriFlow® CFL Meter is a bulk solids mass flow meter specially designed for very low flow rates that can be as low as 100 lb/hr. The CFL Type I, as with all other Type I Meters, is constructed primarily for use after feed devices that move material in a horizontal direction (belt conveyors or vibratory conveyors, for example). Unlike other models of the Type I Meter, the CFL meter typically includes a housing that shelters the Measurement Pan. The CFL Type I Meter is great for free-flowing products and is often used to measure additives, ensure proper ratios of mixtures being blended together, or for any application in which accurate flow measurement of low flow rates of material is important. The CFL is constructed entirely of Stainless Steel. As with the standard CentriFlow® Meter, the CFL would typically require some sort of transition (pictured) if oriented in the In-Line flow configuration. This transition can either be supplied by Eastern Instruments, or by a third party as well.

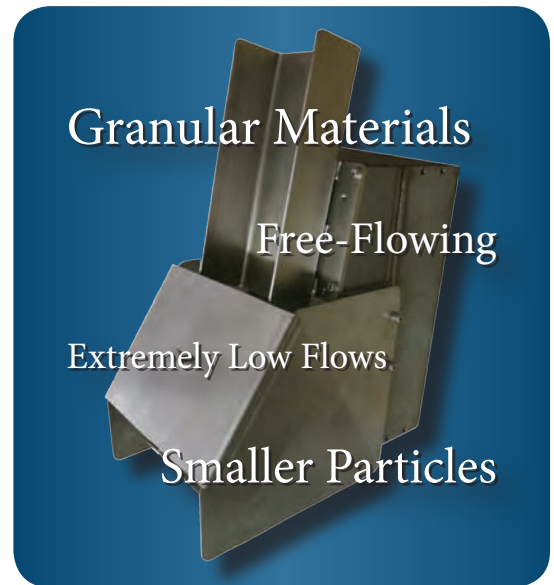

## Material Specification

1. Standard meter parts including the meter body and casing are constructed entirely out of 304 Stainless Steel.
2. Standard product contact surfaces such as the Measurement Pan and Tangential are constructed of Stainless Steel.
3. Stainless Steel Pans are typically of a welded, one-piece constructions and can be manufactured with a variety of coatings as well.
4. Many options for flow surfaces are available and can be substituted for the standard flow surfaces mentioned above. The meter body and casing can be manufactured out of either 304 or 316 Stainless Steel

## Design Specification

- The outer assembly is fully welded which helps maintain the meter's accuracy especially during measurement periods of extremely low flow rates.
- The Pan Assembly as well as the Meter Housing, are both detachable Stainless Steel weldments that are easy to remove for cleaning and maintenance.
- The overall footprint of the CFL Meter is less than 24" in height.
- The intake transition is completely customizable to accommodate any application.

Volumetric Capacity of the CentriFlow® CFL Meter for REVERSE FLOW ft<sup>3</sup>/min (m<sup>3</sup>/hr)

Meter Size	Belt		Vibratory	
	Min	Max	Min	Max
CFL-03	0.13 (0.21)	2.50 (4.25)	0.13 (0.21)	2.50 (4.25)
CFL-06	0.34 (0.57)	6.75 (11.47)	0.34 (0.57)	6.75 (11.47)

Volumetric Capacity of the CentriFlow® CFL Meter for IN-LINE FLOW ft<sup>3</sup>/min (m<sup>3</sup>/hr)

Meter Size	Belt		Vibratory	
	Min	Max	Min	Max
CFL-03	0.13 (0.21)	2.50 (4.25)	0.13 (0.21)	2.50 (4.25)
CFL-06	0.34 (0.57)	6.75 (11.47)	0.34 (0.57)	6.75 (11.47)

## TYPE I CFL SPECS



Top View

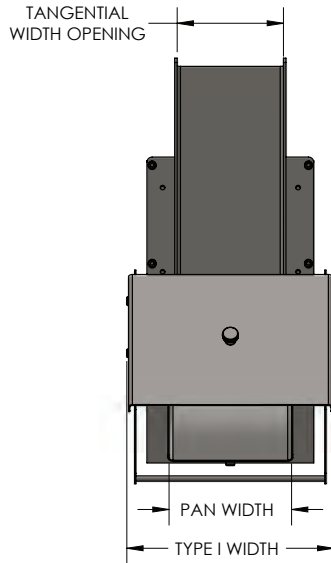

Front View

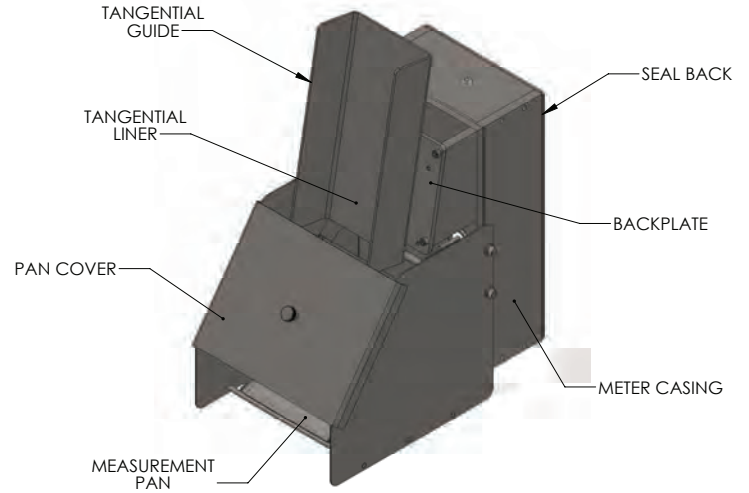

For Meters With  
An Enclosure  
Please See Our  
Type II Catalog

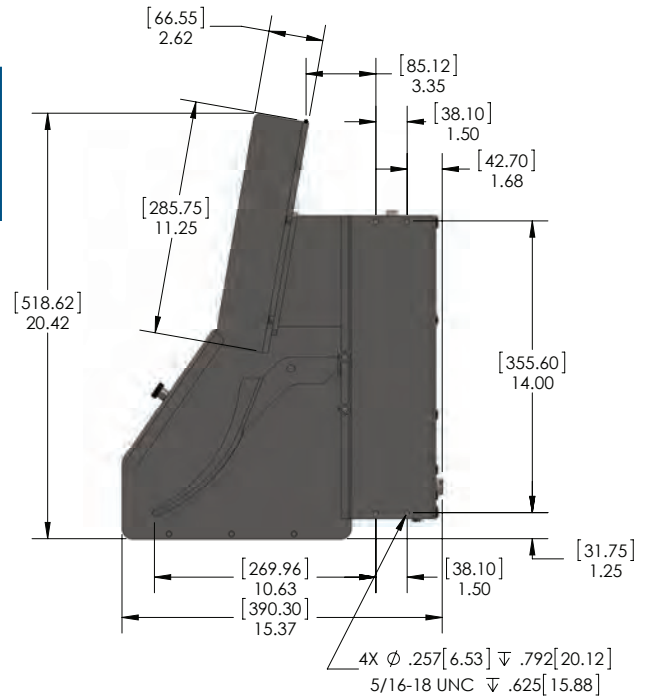

Side View

CFL – Specifications						
	Type I Width	Meter Height	Tangential Opening	Infeed Chute Opening Width	Discharge Dimensions	Weight
CFL-03	10.24 in. 260 mm	28.84 in 733 mm	2.1 in 53 mm	5.00 in 127 mm	8.1 in x 9.5 in 206 mm x 241 mm	85 lb 39 kg
CFL-06	10.24 in 260 mm	28.84 in 733 mm	5.1 in 130 mm	8.00 in 203 mm	8.1 in x 9.5 in 206 mm x 241 mm	85 lb 39 kg

# HDM Type I: Heavy Duty

The CentriFlow® HDM Meter is a bulk solids mass flow meter specially designed for high density products with very high flow rates. As a Type I Meter, the HDM can be utilized for any high-density, high-flow rate application in which the product is being fed by vibratory conveyors or belts. As with the standard meter, the HDM can be oriented in both the In-Line Flow and the Reverse Flow orientation. The main difference is that the HDM Meter is designed to have a much more robust construction, including an increased height and depth for increased flow capacity. Its robust construction makes it perfect for installation in a variety of applications, including the processing of mine tailings; the rapid loading and unloading of trucks, railcars or shipping containers; or any installation where flow rates, bulk densities, or both are exceptionally high.

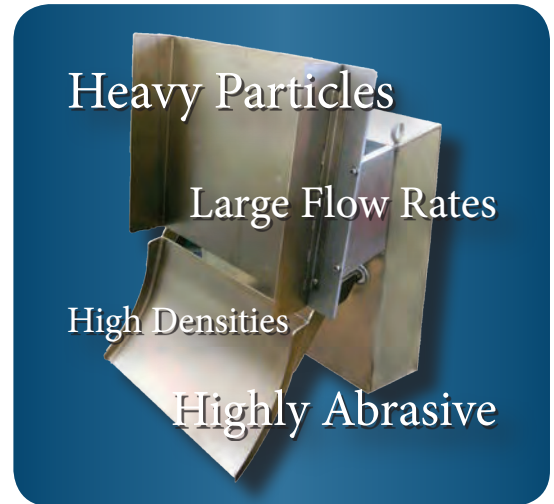

## Material Specification

1. Standard meter parts including the meter body and casing are constructed entirely out of 304 Stainless Steel.
2. Standard product contact surfaces such as the Measurement Pan and Tangential are constructed of Stainless Steel.
3. Stainless Steel Pans are typically of a welded, one-piece constructions and can be manufactured with a variety of coatings as well.
4. Many options for flow surfaces are available and can be substituted for the standard flow surfaces. The meter body and casing can be manufactured out of either 304 or 316 Stainless Steel.

## Design Specification

- Both the depth and the height of a standard meter have been doubled in order to accommodate much larger flow rates.
- The radius of the Pan is doubled to accommodate larger particles and higher flow rates.
- The meter can be installed in two different orientations depending on the installation location for the meter. The Type I (open) meter as shown here and the Type II (enclosed) meter.

*\*Please see the Type II catalog for additional information about the Type II enclosed meter.\**

Volumetric Capacity of the CentriFlow® HDM for REVERSE FLOW ft <sup>3</sup> /min (m <sup>3</sup> /hr)				
	Belt		Vibratory	
	Min	Max	Min	Max
HDM-24	3.75 (6.37)	75.00 (127.43)	37.50 (63.71)	112.50 (191.14)
HDM-48	7.50 (12.74)	150.00 (254.85)	75.00 (127.43)	225.00 (382.28)
HDM-72	11.25 (19.11)	225.00 (382.28)	112.50 (191.14)	337.50 (573.41)

Volumetric Capacity of the CentriFlow® HDM for IN-LINE FLOW ft <sup>3</sup> /min (m <sup>3</sup> /hr)				
	Belt		Vibratory	
	Min	Max	Min	Max
HDM-24	37.50 (63.71)	225.00 (382.28)	37.50 (63.71)	112.50 (191.14)
HDM-48	75.00 (127.43)	450.00 (764.55)	75.00 (127.43)	225.00 (382.28)
HDM-72	112.50 (191.14)	675.00 (1146.83)	112.50 (191.14)	337.50 (573.41)

## TYPE I HDM SPECS

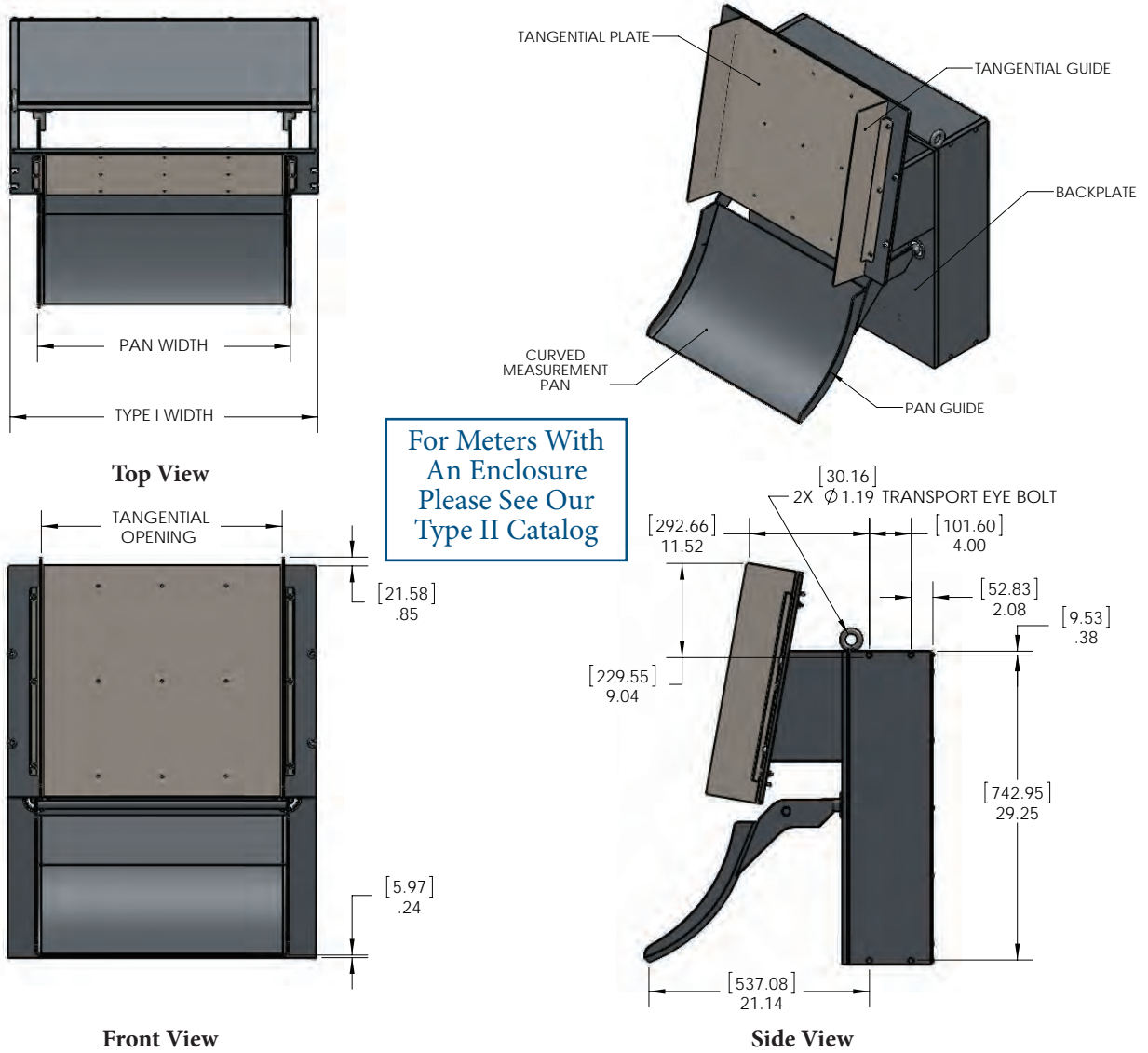

### Type I – Specifications

	Type I Width	Tangential Opening	Pan Width	Height	Weight (SS)	Installation Angle
HDM-24	29.50 in 749 mm	23.10 in 587 mm	24.26 in 616 mm	38.40 in 975 mm	665 lb 302 kg	0° In-Line and Reverse Feed
HDM-48	53.50 in 1359 mm	47.10 in 1196 mm	48.26 in 1226 mm	38.40 in 975 mm	1064 lb 483 kg	0° In-Line and Reverse Feed
HDM-72	77.50 in 1969 mm	71.1 in 1806 mm	72.26 in 1835 mm	38.40 in 975 mm	1596 lb 724 kg	0° In-Line and Reverse Feed

# CentriFlow<sup>®</sup> Options

## MATERIAL OF CONSTRUCTION

### Meter Casing and Enclosure

While the Material of Construction for CFL and HDM style meters is Stainless Steel, the Material of Construction for CFM and LDM style meters is either Aluminum or Stainless Steel. The Stainless Steel models are perfect for corrosion resistance or for Food Grade applications. Most Enclosures are Stainless Steel.

### Flow Surfaces

The flow surfaces of the meter, including the Pan, the Tangential and transitions, can either be a welded, one-piece assembly for applications requiring food grade equipment, or they can be composite assemblies which include interchangeable liners for inexpensive replacement of worn flow surfaces.

### Surface Treatments

The flow surfaces of the meter, including the Pan, the Tangential and transitions can be equipped with a variety of coatings for wear prevention and increased flowability. For extreme wear, tiled flow surfaces are also available. These tiled flow surfaces include 1/16" ceramic tiles that are bonded to flow surfaces, dramatically curbing the effects of wear. If a particular surface treatment or coating works well in your process, we can certainly apply that same coating or finish to our flow surfaces as well. Let us know what works best for your process.

## HEATED PRODUCTS

### High-Temperature Option

The High Temperature Option should be used when products exceed 150°F (66° C). Air is used in order to keep the casing's internal temperature down, while a Stainless Steel Barrier with High Temperature Foam is used to isolate the heat of the product from the meter's internal components.

## COLD PRODUCTS

### Internal Heater

For meters that measure cold products or that are installed in cold environments (or environments with extreme temperature changes) an internal heater is available that will heat the meter's internal components to 140° F (60° C).



Coated Pan for Enhanced Wear Resistance



Curved Corner Pan for Enhanced Flowability



Tiled Pan for Superior Wear Resistance



## SLOW FLOW PRODUCTS

### Pulsed Air System



Air Flow Movement:  
Pulsed Air System

The Pulsed Air System is designed to deliver a pulsed blast of dry, instrument air to the area both above and below the Measurement Pan in a manner that will not adversely affect flow measurement readings. Use of the Pulsed Air System is intended to assist with product flow, as well as to eliminate product buildup on the Pan; which if left unchecked, could result in a less accurate flow measurement.

### Integrated Air Entrainment (IAE)

The Integrated Air Entrainment System is designed to deliver an even stream of air to the CentriFlow® Meter's Measurement Pan. Its continuous, dry air reduces build up and assists in the flow of product on the measurement surface without affecting the measurement readings.



Pan Movement:  
VibraWeigh

### VibraWeigh

The VibraWeigh® option, typically used in powder applications, keeps small particle size materials (down to 10 to 50 microns) from building up on the pan surface. This is important in order to keep the process product flowing through the meter and sliding smoothly on the Pan Liner. Build-up that might divert or impede the flow could result in less accurate flow measurement.

## DUSTY MATERIALS

### Type II Meter Configuration with Enclosure



Standard Type II Meter  
with Enclosure

The CentriFlow® Type II Meter is an adaptation of the Type I Meter that allows the meter to be installed directly after feed devices that move material in a vertical direction such as slide gates, rotary air locks, or screw conveyors. Especially useful for dusty products or powders, the Type II Meter features an enclosure that houses the meter and ensures that the flow path is contained. The housing is flanged on both the intake and discharge chute in order to make installation extremely easy.

### Engineered To Order

Eastern Instruments' engineering department assists on every order with installation concepts and drawings. We are also available to design and build custom enclosures, transitions or even entire systems when required.

# CentriFlow<sup>®</sup> Electronics

## Digital Electronics Package with NEMA-4 White Painted Steel Enclosure

Each CentriFlow<sup>®</sup> Meter comes standard with a digital electronics package encased in a NEMA-4 rated white-painted, Carbon Steel enclosure. The Digital Electronics enclosure can be mounted indoors or outdoors when the necessary precautions are taken and when used in conjunction with NEMA-4-approved conduit. A NEMA-4X Stainless Steel version is also available for applications in which equipment is subject to corrosive wash downs or direct spray.



### SAMPLE SCREENS

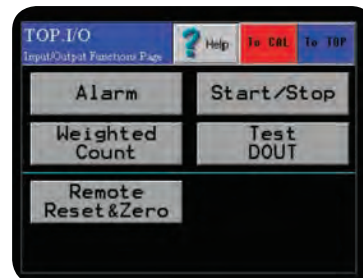
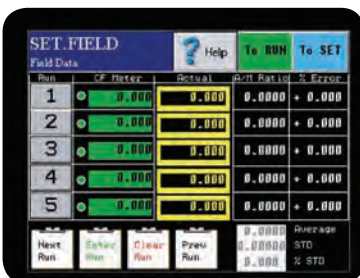
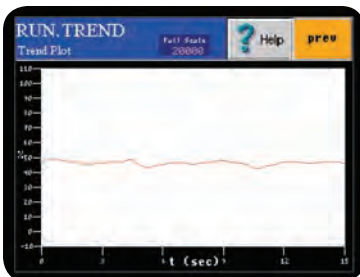
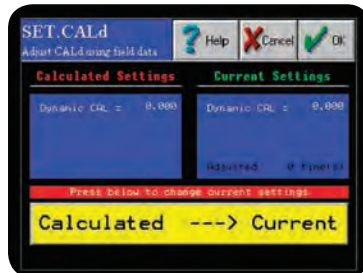
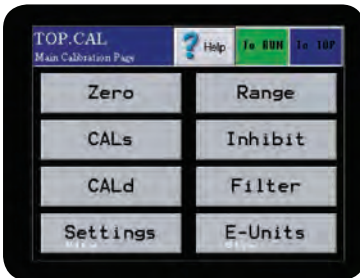

## Features

- 4-20 mA Output (Flow Rate Proportional/Current Sourced/Fully Isolated)
- Frequency Output (Flow Rate Proportional – 0-500 Hz)
- Remote Reset Capabilities
- Flow Rate or Totalization
- Alarm/Preset Capabilities
- Large, convenient, color, touch screen HMI with Flow Rate and Totalization displayed simultaneously on the main screen
- Universal Power Supply (85-264 VAC)
- 2 Gigabyte, Compact, Flash Card that records data every second for up to 1 year
- User-friendly Calibration, including Zero Adjustment, Static Calibration, Dynamic Calibration, Field Calibrations
- HMI On-screen Plotting/Trending
- Supports Ethernet and most industrial protocols
- Programming Control Capability over devices for mixing and blending applications and more!

## NEMA-4 PAINTED/STAINLESS PACKAGE

### Electronics Dimensions

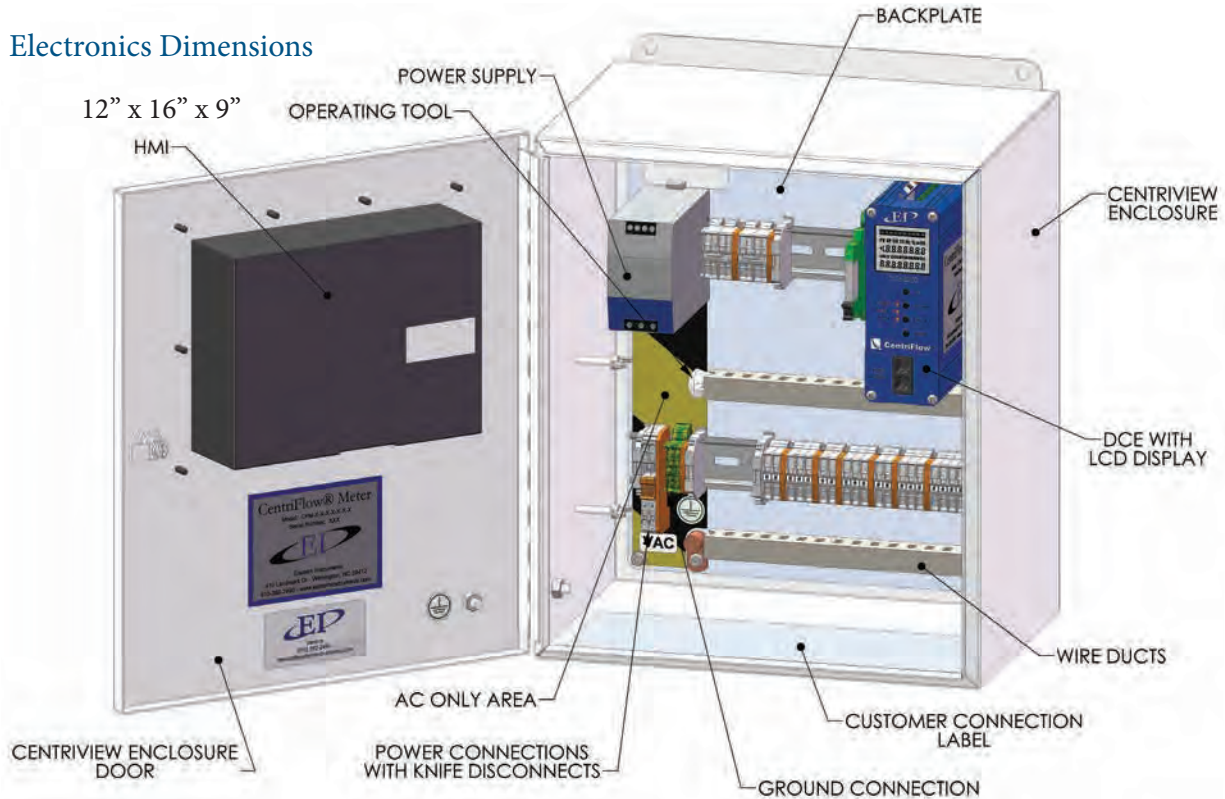

## Additional Options

### Remote Communication Protocol

A variety of optional remote communications protocols are available, including communication via Ethernet/IP, DeviceNet or ProfiBus. The standard data transmitted includes flow and total, the meter's status, zero read back, the internal temperature, an alarm target, calibration values and the ability to remotely reset zero. Additional information is also available upon request.

### Multiple Calibration

If multiple products are to be run through the CentriFlow® Meter, multiple calibration voltages can be stored and selected as each product is run through the meter. Up to 8 values can be stored locally, however, an infinite number of calibration values can be sent to the electronics via one of the remote communications protocols.

### Filtering

Filtering of the rate signal allows for the smoothing of the instantaneous flow rate output delivered by the CentriFlow® Meter. Filtering of the rate signal can be accomplished both locally on the HMI, or by using the remote signal that is sent via any remote communication protocol. Filtering can be accomplished at intervals ranging from .1 seconds up to 10 seconds.

### Weighted Count

The Weighted Count Option allows for the generation of a much slower pulse output of your total for applications that would otherwise need a High Speed Counter Card to read the 500 Hz Frequency standard flow rate signal. (Example: 1 pulse/100 lb).



Copyright 2015 Eastern Instruments  
Protected by US Patents 5,219,031; 5,230,251; 6,732,597;  
6,640,158; 6,814,108; 6,679,125. Other patents pending.

416 Landmark Drive  
Wilmington, NC 28412  
Phone: 910.392.2490  
Fax: 910.392.2123

[www.easterninstruments.com](http://www.easterninstruments.com)